

PRESSURE ADJUSTMENTS FOR THE BIENFANG MECHANICAL PRESS (JUMBO 160-160M, COMMERCIAL 210-210M, MASTERPIECE 500T, MASTERPIECE 250/550)

Remove existing parts

1. Disconnect press from electrical supply.
2. Lock press handle closed.
3. Completely remove adjusting nut by turning counterclockwise. (Two pieces on 210 and 500T press)
4. Return press handle to open position.
5. Reaching beneath crossbeam, turn adjusting bolt clockwise until it clears the beam. (Two pieces on 210 and 500T press)
6. Slide entire top assembly forward on sponge pad as far as it will go.
7. Remove spring washer. (Two pieces on 210 and 500T press)
8. Completely remove adjusting bolt by turning it counterclockwise. (Two pieces on 210 and 500T press)

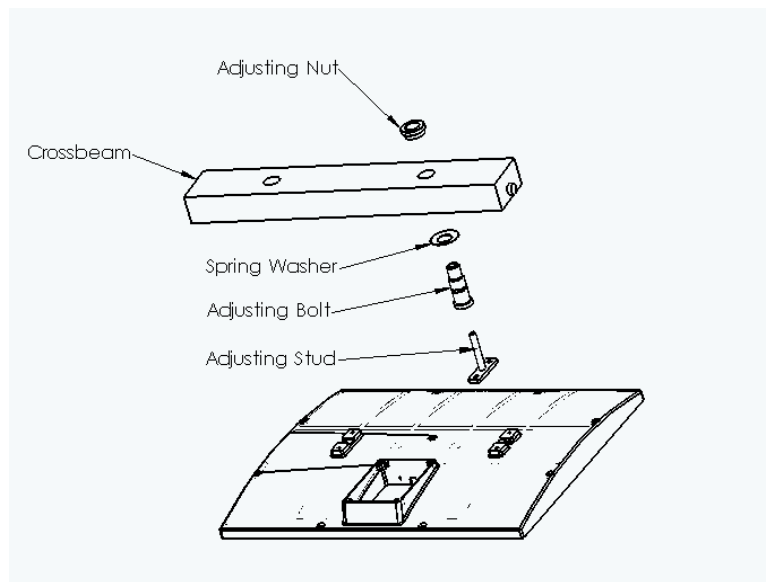

NOTE: Adjusting stud can also be removed if necessary at this time by removing the fastening screws.

Install New Parts

9. Follow above steps in reverse order to install new parts.

Pressure Adjustment

1. Put material in press. (Bienfang Foam Board or mat board)
2. Close the press in the locked position.
3. Unscrew adjusting nuts and remove.

4. Open lid.
5. Turn adjustment screws.
 - Counter Clockwise- Increase Pressure, Raise Lever Arms
 - Clockwise- Decrease Pressure, Lower Lever Arms
6. Close lid and screw on adjusting nuts.

*Work with it until it feels comfortable.